

DW

Refrigeration dryers

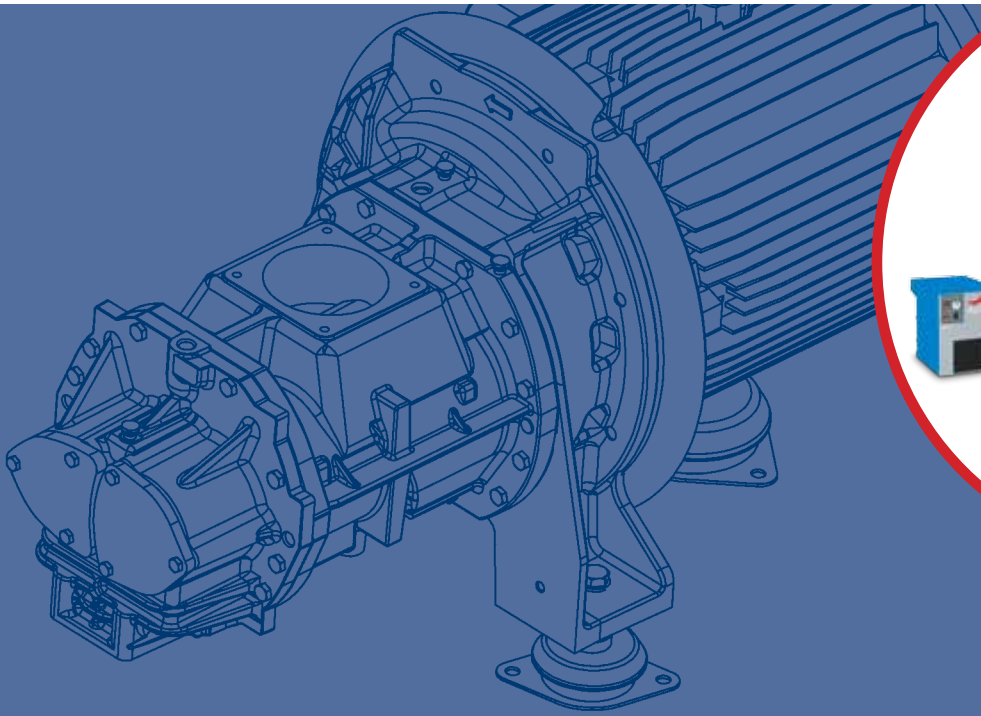

DW 2-504

Worthington Creyssensac

Driven by technology. Designed by experience.

Worthington Creyssensac has 145 years of industrial experience. It is our ambition to offer compressed air solutions that ensure we are first in choice for our customers. To reach this goal we continuously invest in our product development to make sure that we are always able to offer:

- High performance and excellent quality
- Integrated engineered solutions
- Full energy efficiency
- Total cost of ownership
- Environmental care

www.airwco.com

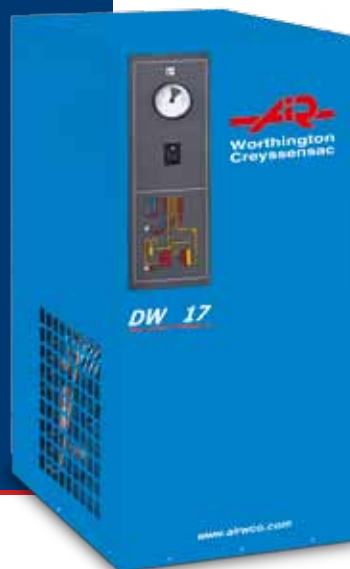

The benefits of refrigeration dryers

During the compression process, a compressor turns humidity in the intake air into condensate. This will cause wear and corrosion to the compressed air network and downstream equipment. The results are costly interruptions to production, and reduction in the efficiency and service life of the equipment used. Refrigeration dryers provide a solution to prevent these negative consequences reaching a PDP of maximum +3°C.

Clean and dry air

- Compressed air is cooled down by refrigerant gas, condensing the water in the air, making it easy to remove.
- Protection of the air network from corrosion, rust and leakages.
- Higher final product quality.



Easy installation

- Very compact design.
- Easily installed, also in limited spaces thanks to the small footprint.
- Easy and fast installation of the filters and by-pass option.



User-friendly operation

- Refrigeration technology is straightforward and requires little maintenance.
- Quick air quality check via dew point display.
- Compatible with any compressor technology and complying with over 95% of the industrial applications.

Multiple air treatment solutions from Worthington Creyssensac

Oil and dust filtration

Our network filters are ideal for the treatment of residual oil and dust particles. Depending on the filtration level, our D filters capture and eliminate:

- Particles down to 0.01 micron such as smoke and dust.
- Oil particles at concentrations as low as 0.005 mg/mc.

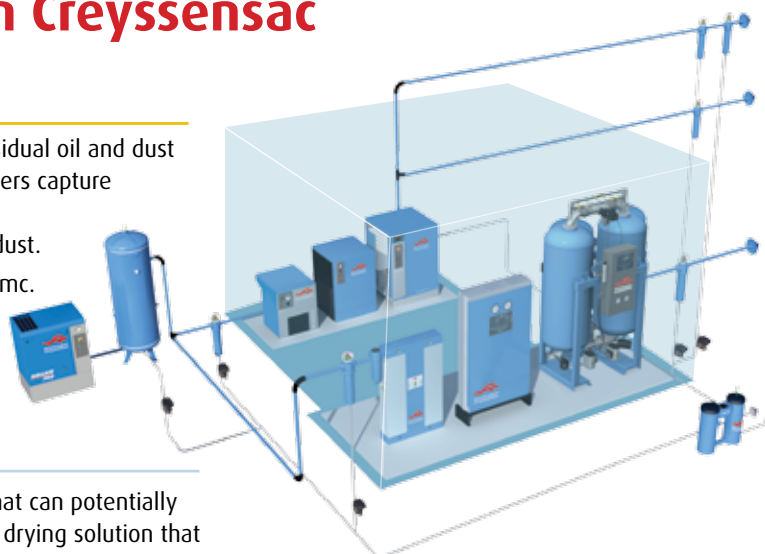

Water separation

Our air drying solutions eliminate the water vapor that can potentially condense in your compressed air system. Select the drying solution that best meets your needs:

- The DW refrigeration dryer eliminates water down to a pressure dew point of 3°C.
- The DB adsorption dryer eliminates moisture down to a dew point as low as -40°C or -70°C depending on the dryer type.

Condensate treatment

- Capacitive condensate drains allow easy discharge of condensate throughout the complete compressed air chain to ensure zero air loss.
- Our S oil-water separator will clean the removed condensate in order to be in line with local environmental legislations.

Protect your compressed air installation against:



Moisture



Particles



Oil



Hydrocarbons



Viruses



Bacteria

Enjoy the benefits of Quality Air Solutions

With air treatment		Without air treatment
Immediately	Eliminate the water/dust produced during the compressing process	Goes to the net
Ensure	Your air network is clean and protected against rust	High risk
Secured	A clean air network reduces leakages	High risk
Prolong	The life span of your operation process (machine, equipment etc.)	Shorten
Protect	Safe use of pneumatic tool, with extended life time	Harm
Lower	The cost of maintenance of your air network (corrosion), operation process and potential downtime	Increase
Improve	Quality of the final product, and potential risk of product recalls	Decrease
Stable	Operating cost control	Variable
Boost	Your productivity	Reduce

Air drying principle

For many companies in today's competitive global market, the treatment of compressed air is not an option, but a necessity in view of operating costs and increased production efficiency. Based on an efficient and simple technology, refrigeration dryers represent the preferred solution for the majority of these applications.

The Worthington Creyssensac DW dryers have been developed to supply dry compressed air for your production process, with a minimum power requirement and low pressure drop for optimum efficiency. Refrigerant dryers use a refrigerant gas in order to cool the compressed air. As a result the water from the air condenses and can be removed and a maximum pressure dew point of +3°C can be reached.

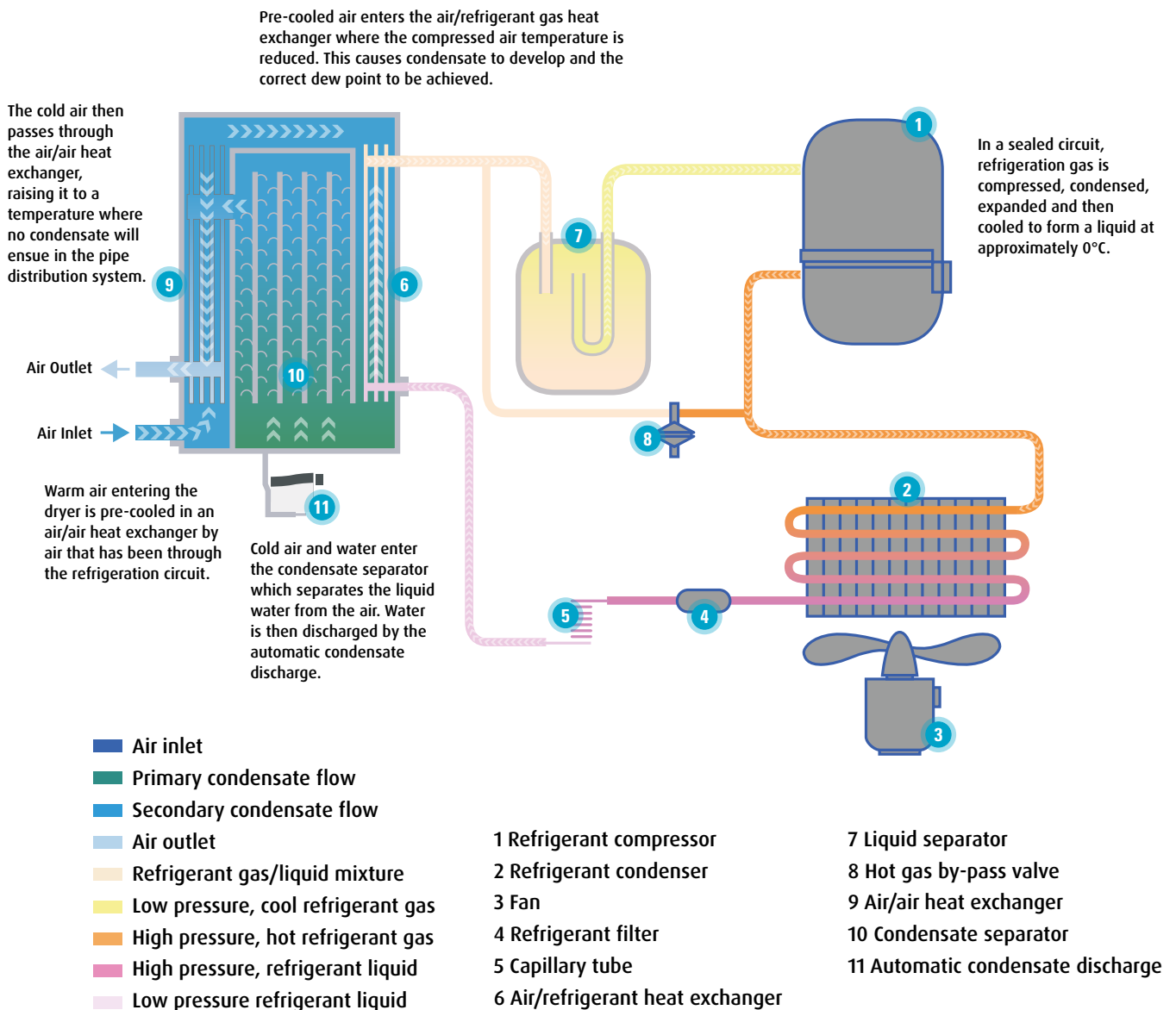

USER BENEFITS

Boost your productivity

- Quality components ensure low pressure, stable pressure dew point and efficient cooling.
- Clean and dry compressed air increases the overall productivity of your operations.

Cost-efficient solution

- No or very little maintenance required.
- Very low energy consumption & high energy saving due to low pressure drops throughout the system.

Easy installation and access

- Compact design, small footprint and simple layout.

User-friendly operation

- Straightforward control panel with easy access to all the electrical components.
- Easy reading from dew point display (for DW 60 - 504).



Environmental friendly refrigerant gases

A key objective in the design of the DW dryer was to deliver a product that offers performance, reliability and safety with the lowest possible environmental impact.

- Environmentally friendly thanks to the use of R134a, R404A and R410A gas.
- No impact on the ozone layer.
- Gas R410A with:
 - Very low Global Warming Potential (GWP)
 - Energy saving by use of rotary refrigerant compressor



Intelligent capacitive drain discharge

The full refrigerant dryer range is equipped with the capacity condensate drain, a newly introduced range using electronic level sensors to discharge only condensate and not your expensive to produce compressed air.

Benefits

- Inherent Energy saving by discharging only condensed water, without wasting any compressed air.
- Automatically adapts to differing condensate levels throughout the year without the need for continual manual monitoring.
- Quiet and safe condensate discharge operation as no compressed air escapes.

The draining process

The condensate enters through the connection (1). The tank (2) collects the liquid and the diaphragm (3) keeps the drain hole closed. When the liquid level increases, the floater (4) goes up and after reaching the highest level, the solenoid valve (5) controlled by the logic circuit, opens the pilot valve (6). The liquid is discharged and when it reaches a minimum level, the diaphragm closes the draining hole again without letting any compressed air out. A filter (7) and a flow regulator (8) in the hose holder (9) have been added.

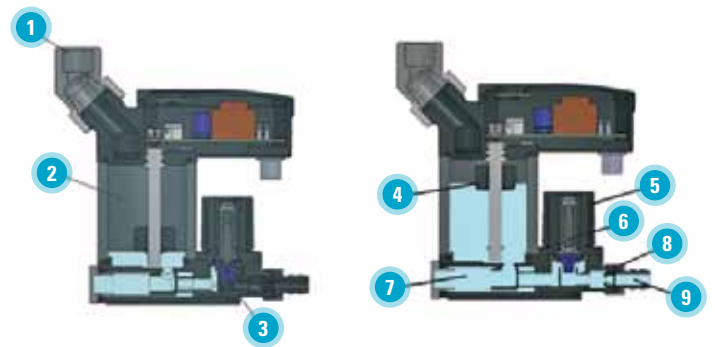

Standard features (for DW 144 - 504)

- Remote start/stop contact
- Remote free contacts for a:
 - General alarm
 - Drain alarm only for ADQ1440 up to ADQ5040

Available options (for DW 2 - 10)

Bypass valve and filter support*

The optional bypass facility allows the system to operate using the filters only during maintenance or malfunction of the dryer, thus avoiding any downtime.

Filter support*

This option allows two filters to be installed on the rear side of the dryer, reducing overall dimensions and installation costs.

* Filters are not included in the option.



Technical data

Type	Flow treated according to temperature of compressed air input						Nominal electrical power ¹	Power supply voltage	Max. operating pressure		Refrigerant gases	Air connections	Weight
	35 °C ¹		40 °C		45 °C				bar	psi			
	m ³ /h	cfm	m ³ /h	cfm	m ³ /h	cfm							
DW 2	21	12.4	17.2	10.2	14.5	8.6	0.13	230/50/1	16	232	R134a	3/4" M	19
DW 3	36	21.2	29.5	17.4	24.8	14.6	0.16	230/50/1	16	232	R134a	3/4" M	19
DW 5	51	30.0	41.8	24.6	35.2	20.7	0.19	230/50/1	16	232	R134a	3/4" M	20
DW 7	72	42.4	59.0	34.8	49.7	29.3	0.27	230/50/1	16	232	R134a	3/4" M	25
DW 10	110	64.4	90.2	52.8	75.9	44.4	0.28	230/50/1	16	232	R134a	3/4" M	27
DW 13	141	83.0	116	68	97	57.3	0.61	230/50/1	13	188	R404A	1" F	44
DW 17	180	106	148	87	124	73	0.67	230/50/1	13	188	R404A	1" F	44
DW 21	216	127	177	104	149	88	0.79	230/50/1	13	188	R404A	1" 1/2 F	53
DW 25	246	145	202	119	170	100	0.87	230/50/1	13	188	R404A	1" 1/2 F	60
DW 31	312	184	256	151	215	127	1.07	230/50/1	13	188	R404A	1" 1/2 F	65
DW 39	390	230	320	189	269	159	1.19	230/50/1	13	188	R404A	1" 1/2 F	80
DW 46	462	272	379	223	319	188	1.45	230/50/1	13	188	R404A	1" 1/2 F	80
DW 60	600	353	492	289	414	244	1.32	400/50/3	13	188	R410A	2" F	128
DW 72	720	424	590	348	497	293	1.63	400/50/3	13	188	R410A	2" F	146
DW 90	900	530	738	435	621	366	1.89	400/50/3	13	188	R410A	2" F	158
DW 108	1080	636	886	522	745	439	2.11	400/50/3	13	188	R410A	2" F	165
DW 144	1440	848	1181	695	994	585	3.90	400/50/3	13	188	R404A	3" F	325
DW 180	1800	1060	1476	869	1242	731	4.46	400/50/3	13	188	R404A	3" F	335
DW 210	2100	1237	1722	1014	1449	854	5.55	400/50/3	13	188	R404A	3" F	350
DW 270	2700	1589	2214	1303	1863	1097	6.71	400/50/3	13	188	R404A	DN 125	380
DW 300	3000	1766	2460	1448	2070	1219	6.80	400/50/3	13	188	R404A	DN 125	550
DW 420	4200	2472	3444	2027	2898	1706	10.20	400/50/3	13	188	R404A	DN 125	600
DW 504	5040	2966	4133	2432	3478	2047	12.30	400/50/3	13	188	R404A	DN 125	650

¹ Reference conditions:

- Operating pressure: 7 bar (100 psi).
- Operating temperature: 35°C.
- Room temperature: 25°C.
- Pressure dew point: +3°C (+/- 1.)
- Available in different voltages and frequency values.

Limit conditions:

- Working pressure: 16 bar (232 psi) (DW 2 up to 10), 13 bar (188 psi) (DW 13 up to 504).
- Operating temperature: 55°C.
- Minimum/maximum room temperature: +5°C/+45°C.

Correction factors to be used for site conditions outside of normal reference conditions (1) stated above = A x B x C

Room temperature	°C	25	30	35	40	45									
	A		1.00	0.92	0.84	0.80	0.74	(DW 2 up to 46)							
		1.00	0.91	0.81	0.72	0.62	(DW 60 up to 504)								
Operating temperature	°C	30	35	40	45	50	55								
	B		1.24	1.00	0.82	0.69	0.58	0.45	(DW 2 up to 46)						
		1.00	1.00	0.82	0.69	0.58	0.49	(DW 60 up to 504)							
Operation pressure	bar	5	6	7	8	9	10	11	12	13	14	15	16		
	C		0.90	0.96	1.00	1.03	1.06	1.08	1.10	1.12	1.13	1.15	1.16	1.15	(DW 2 up to 46)
			0.90	0.97	1.00	1.03	1.05	1.07	1.09	1.11	1.12	-	-	-	(DW 60 up to 504)

The new flow rate value can be obtained by dividing the current or real flow rate by the correction factor related to the real operation conditions.

Dimensions	A	B	C	Dimensions	A	B	C
	mm				mm		
DW 2 up to 10	350	484	511	DW 60 up to 108	735	1016	898
DW 13 up to 17	370	764	515	DW 144 up to 270	1020	1560	1082
DW 21 up to 31	460	789	575	DW 300 up to 504	1020	1560	2099
DW 39 up to 46	580	899	604				





**Worthington
Creysensac**

DRIVEN BY TECHNOLOGY DESIGNED BY EXPERIENCE



**CONTACT YOUR LOCAL
WORTHINGTON CREYSSENSAC
REPRESENTATIVE**

6999010162

www.airwco.com